

SIMULATION OF THE PLASTIC DEFORMATION PROCESS FOR MANUFACTURING THE TOOTHING IN FLAT WHEEL STRAIN WAVE GEARING

Gábor Brezvai, BSc

Robert Krisch, PhD

Budapest University of Technology and Economics

Department of Machine- and Product Design

ABSTRACT

The functions of the principal members of a flat-wheel strain wave gearing are similar to the functions of a traditional harmonic drive, but the feature of the flexible and the solid wheels are different. Both of the gears have a large number of teeth; therefore manufacturing of these parts is very expensive. This paper reports an investigation about plastic deformation, as a possible way of manufacturing the tothing of the gears. The coining process was simulated with finite element method and the pressing force was determined for the tothing parameters of an existing experimental drive.

1. INTRODUCTION TO FLAT WHEEL STRAIN WAVE GEARING

As for the function principle of the flat wheel strain wave gearing (Figure 1) [1], it is similar to the basic principle of the classical harmonic drives [2]; it could be regarded as a special variety of them. The flexible and the rigid gear of the drive are coaxial flat wheels. The cam-type wave generator (G) consisting of a flexible axial bearing and a disc with cams, deforms the flexible gear (1) in axial direction periodically and elastically, the tothing of which comes into mesh with the tothing of the rigid gear (2).

SOLID GEAR (2) FLEXIBLE GEAR (1) WAVE GENERATOR (G)

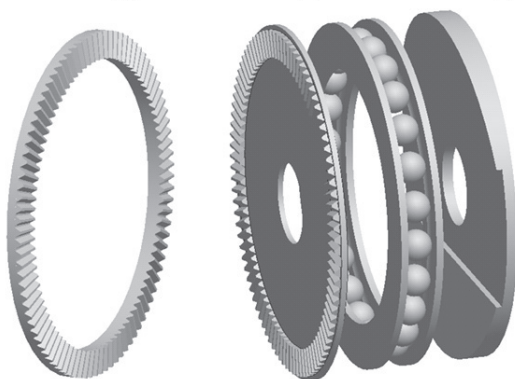

Figure 1: Basic parts of flat-wheel strain wave gearing

Figure 2 shows the schematic representation of the engagement, where ϕ is the polar angle from the top of the deformation wave made of the wave generator, $\phi = 0^\circ$ means the

symmetry plane of the deformation wave. Since the flexible and rigid gears have a different number of teeth, there will be a relative rotational motion between the flexible and the solid gear. The kinematic ratio of the investigated strain wave gearing, in case of rigid gear is fixed, flexible wheel connects to the output shaft, wave generator connects to the input shaft, can be calculated as the following:

$$i_{12} = \frac{z_1}{z_1 - z_2} \quad (1)$$

where z_1 describes the number of teeth of the flexible wheel, z_2 describes the number of teeth on the rigid wheel.

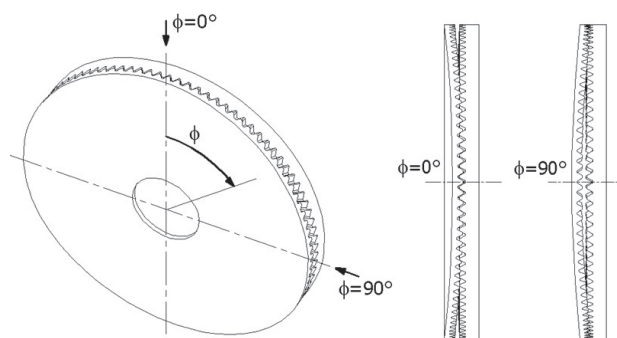

Figure 2: Schematic representation of the engagement in flat-wheel strain wave gearing

2. COINING - A POSSIBLE WAY OF MANUFACTURING THE TOOTHING

Wheels of strain wave gearing have a large number of teeth: usually $z > 100$. In case of flat wheel drive $z > 160$ [1].

Manufacturing the tothing of the wheels by traditional tothing methods or by milling is very expensive that was the reason why other solutions were examined. Coining [3] is a form of precision stamping in which a workpiece is subjected to a sufficiently high stress to induce plastic flow on the surface of the material. A beneficial feature is that in some metals, the plastic flow reduces surface grains size, work hardening the surface, while the material deeper in the part retains its toughness and ductility. Coining is used to manufacture parts for all industries and is commonly used when high relief or very fine features are required. It is a cold working process (similar to forging which takes place at elevated temperature) that uses a great deal of force to plastically deform a workpiece, so it conforms to a die. Coining typically requires higher tonnage presses than stamping, because the workpiece is plastically deformed and not actually cut, as in some other forms of stamping. The term comes from the initial use of the process: manufacturing of coins. In this article the coining process was examined to determine the pressing force needed for the forming. The process was simulated with finite element method.

3. TOOTHING PARAMETERS

In a previous study [1] an analytical method has been developed for examining backlash condition and for determining of tothing parameters for the proper function of flat wheel strain wave gearing. Tooth flanks were approximated by planes. Main sizes and tothing parameters of the examined drive were determined (hereafter index '1' means the flexible, '2' the solid wheel):

- $d_k = 100$ mm – outer diameter of tothing;
- $d_b = 75$ mm – inner diameter of tothing;
- $v = 1$ mm – thickness of flexible wheel;
- $w_0 = 1,2$ mm – axial deformation;
- $z_1 = 200, z_2 = 198$ - numbers of teeth;

Tooth profile parameters at the middle diameter:

- $h_{a1} = h_{a2} = 0,39$ mm - addendum height;
- $h_{f1} = h_{f2} = 0,26$ mm - dedendum height;
- $c_1 = c_2 = 0,1$ mm – clearance;
- $\alpha_1 = 29^\circ, \alpha_2 = 30^\circ$ - profile angles;
- s_1, s_2 - thicknesses at pitch line are halves of pitch;

Simulations were launched for the parameters on the middle diameter.

4. THE FINITE ELEMENT MODEL

To estimate the magnitude of the force it is necessary to simplify the model. In the 2D model shown in Figure 3, along the pitch circle a cylindrical section is used. The finite element model is created manually. Metal forming simulations require remeshing during the analysis. In this case a global remeshing criteria is used in every second increment while the number of elements is constantly 4000.

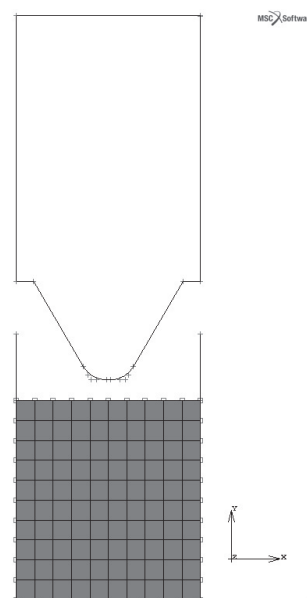

Figure 3: The finite element model

Element properties:

- Element type: 2D quadrilateral
- Plain strain elements
- Element thickness: 12.5 mm
- Number of elements:
 - Start with: 100
 - After first remeshing: 4000
- Number of nodes:
 - Start with: 121
 - After first remeshing: 4505

Material properties:

Isotropic material model is used for the workpiece and the tool is considered a rigid body. The elastic-plastic material model is added with the isotropic hardening rule.

Properties:

- Young's modulus: 210000 MPa
- Poisson's ratio: 0,3
- Yield stress: 270 MPa

Boundary conditions:

The tool has a constant 0.3 mm/s velocity in negative y direction for 1.82 second. The horizontal border in the bottom of the die supports the vertical restraint, and 2 vertical rigid walls ensure the symmetry constraints.

Contact pairs properties:

Boundary curves describe the contour of the rigid tool. The friction coefficient is 0.12 between the contact pairs. The numerical solver uses a displacement-based model of friction.

5. RESULTS

As a result of the load reaching the yield stress, the workpiece adapts to the shape of the tool. (Figure 4). Figure 5 shows stress results throughout the process.

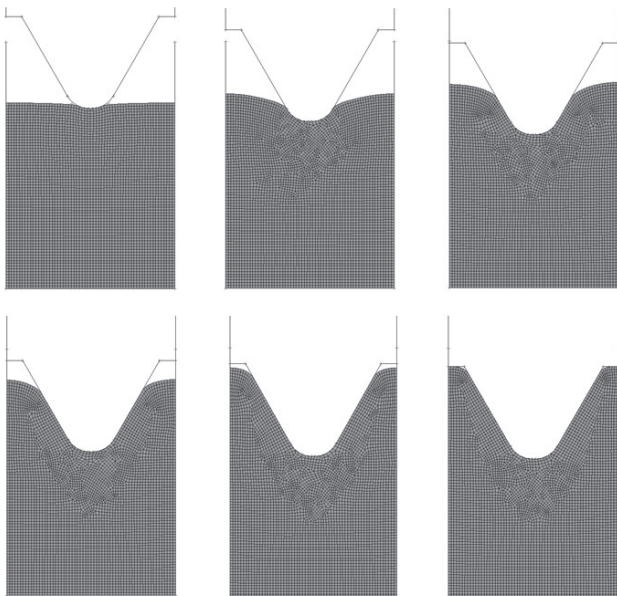

Figure 4: Shape-changes during the process

The pressing force can easily be calculated with contact normal stresses rising on the bottom of the die. The average of the contact normal stresses is multiplied by the area of the contact surfaces and the number of teeth. The result is a reaction force which is equal to the pressing force needed for the flexible wheel's forming throughout the process (Figure 6).

It is shown on the last picture of. Figure 4 that the top of the tool contacts to the workpiece. That is why the pressing force is increasing sharply at the end of analysis (Figure 6).

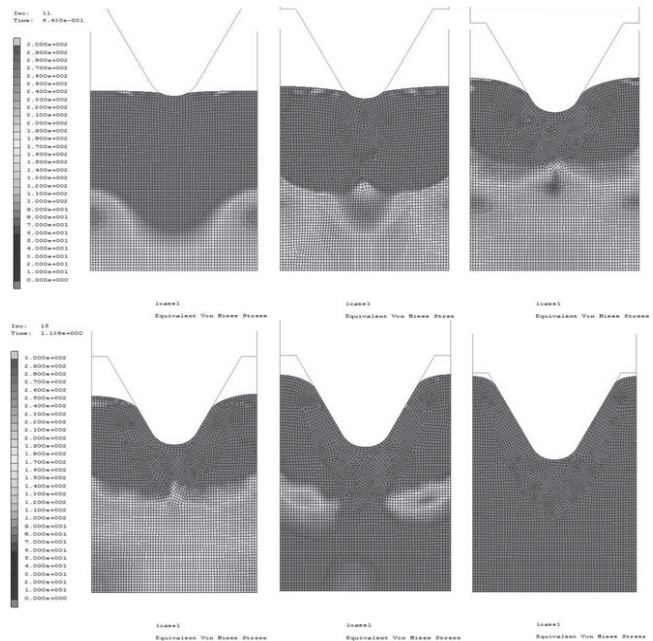

Figure 5: Stress distributions during the process

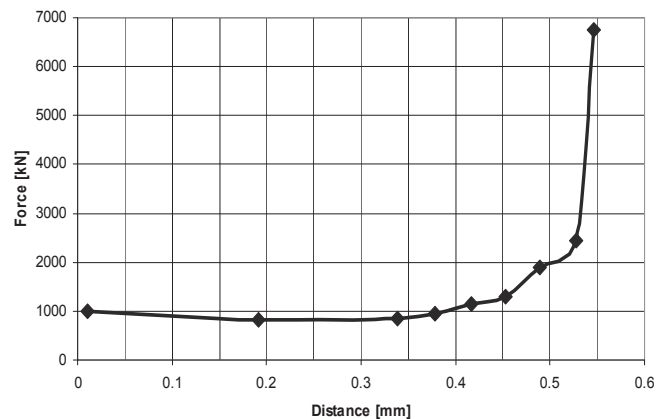

Figure 6: The pressing force vs depth of penetration

6. REFERENCES

- [1] Krisch R: Development of flat wheel harmonic gear drives, PhD thesis, 2009 Budapest University of Technology and Economics
- [2] www.harmonicdrive.de
- [3] [http://en.wikipedia.org/wiki/Coining_\(metalworking\)](http://en.wikipedia.org/wiki/Coining_(metalworking))