



# ALKALINE MOLARITY RATIO FOR SUSTAINABLE DESIGN OF BUNKER USING GEOPOLYMER CONCRETE - A GREEN CONCRETE APPROACH

**A Mohan<sup>a</sup>, Faiz Ahmed<sup>b</sup>, Mickel Gastro S<sup>b</sup>, Vignesh K<sup>b</sup>**

<sup>a</sup>Assistant Professor, Department Of CivilEngineering , Easwari Engineering  
College, Ramapuram, Chennai

<sup>b</sup>UG Student, Department Of CivilEngineering , Easwari Engineering College,  
Ramapuram, Chennai

Mail id : [mohananbarasu@gmail.com](mailto:mohananbarasu@gmail.com)

---

**Article History:**Received: 08.12.2022

Revised:18.1.2023

Accepted: 7.02.2023

---

## Abstract

The project involves the Planning, Analysis and Design of a Bunker. The analysis and design involves planning and drafting, structural analysis, load calculation, design calculation, and checking done by modelling using STAAD-Pro V8i, the manual design of vertical slab , design of columns, the design of beams and design of footing is done by limit state method as per Indian standard. Analysis has been done for various load combinations including seismic load, wind load, etc, as per the Indian Standard Code of Practice. The project involves a comparison between reinforced concrete and geopolymer concrete. Finally, Estimation and costing are done as per the schedule of rates.

Key words : Geopolymer concrete, sustainable , Bunker, Green concrete

---

**DOI: 10.31838/ecb/2023.12.2.010**

## 1 INTRODUCTION

Bunkers and silos are structures that are used as storage tanks. The structural design of bunkers with the procedure and design considerations are discussed. The bunkers and silos made of reinforced concrete have almost replaced the steel storage structures. Concrete bins possess less maintenance and other architectural qualities greater than steel storage tanks. They are used to store materials like grain, cereals, coal cement etc. They both serve the purpose of bins. The concept and difference between bunkers and silos are explained in the following sections: Bunkers are mainly employed for the storage of underground dwellings. These are mainly related to emergency conditions during wars.

The main two characteristics that make a bin act as a bunker is based on the

- Depth(H)
- Angle of rupture

These are characterized as shallow structures. The angle of rupture of the material in case of bunkers, will meet the horizontal surface at the top of the bin, before it touches the opposite side wall of the structure as shown in the figure. Bunkers may be circular or rectangular (or square) in plan.

---

The main structural elements that constitute a bunker. They comprise of

- Vertical walls
- Hopper Bottom
- Edge Beam (At the top level)
- Supporting Columns

## 2 OBJECTIVES

- To plan, analyze and design a bunker using geopolymer concrete
- To find an alternative for OPC concrete.
- To provide high-strength geopolymer concrete than ordinary Portland concrete.
- To calculate the optimum design mix of geopolymer concrete for storage structures.

## 3 SCOPE

- To design a durable and sustainable infrastructure for storage using geopolymer concrete.
- Providing a viable use for waste materials which are often disposed of in landfills.
- Better thermal insulation properties
- To make emission-less transparent concrete.
- To make economical and eco-friendly concrete.

## 4 DESIGN OF BUNKER

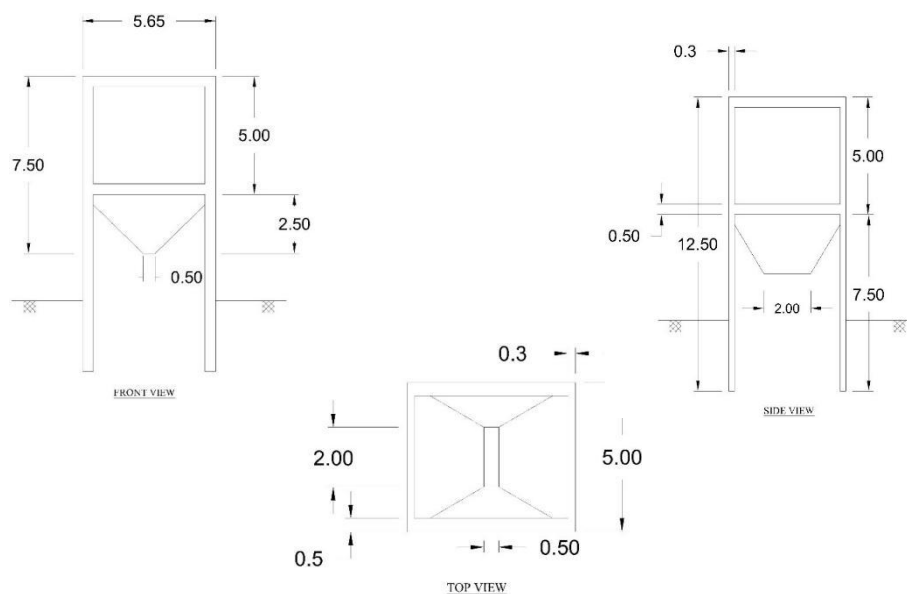

All dimensions in mm

**Figure 1: design details of bunker**

---

## 5 LOADCONDITION OF BUNKER

### **Dead Load:**

Dead loads shall include the weight of all structural components such as beams, , columns and walls and other permanently applied external loads. In solid storage structures, the dead loads shall be calculated by taking the weight of the components such as ring beams, stiffeners, internals and shell. The dead loads are static forces exerted in the vertical plane and are relatively constant throughout the lifetime. The building materials are not considered dead loads till they are constructed in the position permanently. The unit weight of the building materials, parts and components are given in the Indian Standard IS 456 – 2000 “Code of Practice for Design loads for buildings and structures”.

### **Live Load:**

Live loads are temporary loads which occur over a short duration of time. The imposed loads are produced by live loads, dust loads, minor equipment loads, erection loads, operation/maintenance loads and loads produced by personnel, tools, and other items placed on the structure, but not permanently attached to it. The floor live loads and roof live loads are to be taken for the load calculation of the solid storage structure. Unless specified otherwise, the minimum live load values are to be considered as per the IS specifications

### **Seismic Load:**

The inertia force created by ground accelerations during an earthquake result in seismic loads. The application of earthquake-generated agitation to the building structure is the concept of seismic load. The mass of the building, the dynamic properties, intensity, duration, and frequency of the ground motion are the functions on which the magnitude of loads depends. The national building codes prescribed the requirements of buildings under seismic performance. Seismic analysis for the foundation of solid storage structure is determined as per IS 1893 – 2002 “Criteria for Earthquake resistant design of structures. The seismic pressure on the solid storage structure walls is calculated as per the guidelines for calculations of seismic actions provided by Indian standards.

### **Load combination (as per IS 456:2000):**

More than one type of load that acts on the structure will result in the load combination. The load combination is to be calculated for the structure that contains more than one type of loading. As per the Building codes, the safety of the structure is ensured by specifying the load combinations with the factors

$$1.5(DL+LL)$$

$$1.5(DL+WL)$$

$$1.2(DL+LL+SL)$$

$$1.2 (DL+LL+WL)$$

$$(0.9 \times DL + 1.5 \times SL)$$

$$(0.5 \times DL + 1.5 \times WL )$$

## 6 STRUCTURAL MODELLING

The bunker is modelled in STAAD PRO software as 3-D SPACE FRAME. Joint Coordinates, Member Incidences, Member Property, and Supports are defined in STAAD INPUT. The calculated loads are applied under individual load cases followed by Load Combination specified as per IS 456: 2000

**Figure 2: structural detailing of bunker**

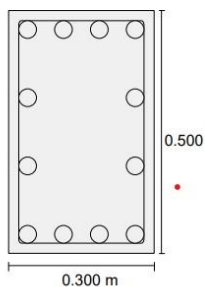
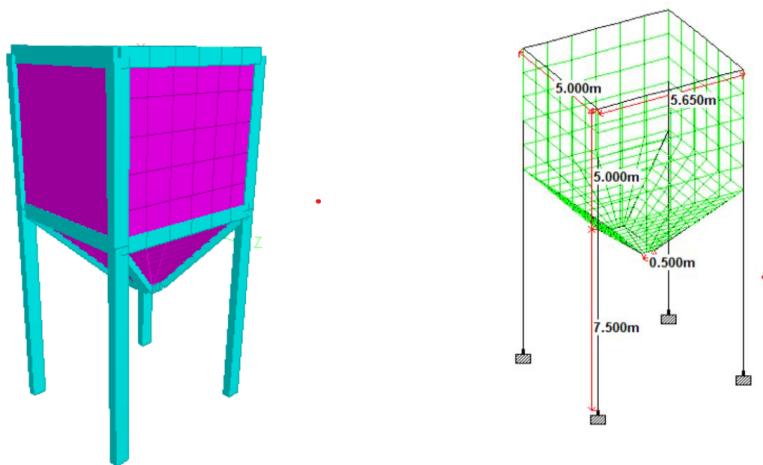

**Design Parameter**

Fy(Mpa)	415.000000
Fc(Mpa)	30.000000
Depth(m)	0.500000
Width(m)	0.300000
Length(m)	0.941663

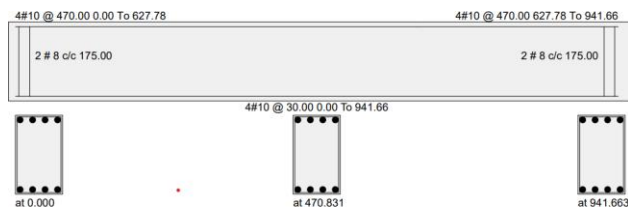

Fy(Mpa)	415
Fc(Mpa)	30
As Reqd(mm <sup>2</sup> )	1200.000000
As (%)	0.905000
Bar Size	12
Bar No	12

## 7. Mix design

### STEP 1: Fix the Alkaline Activator Solution (AAS) Content

From the trials carried out in the laboratory it was found that at an AAS content of 200 kg/m<sup>3</sup> GPC can be developed effectively with better strength, workability, and economy.

### STEP 2: Determination of Strength

$$\begin{aligned} F_{ck} &= f_{ck} + (1.65 * 5) \\ &= 35 + 8.25 \end{aligned}$$

$$F_{ck} = 43.25 \text{ Mpa}$$

AAS/FA ratio is 0.4

### STEP 3: Calculation of Binder Content

$$\text{Binder content (BC)} = \text{AAS content} / (\text{AAS/FA})$$

$$\text{BC} = 200 / 0.4 = 500 \text{ kg/m}^3$$

### STEP 4: Calculation of individual activator solution contents

For all the mixes the Na<sub>2</sub>SiO<sub>3</sub> and NaOH ratio employed was 1.5, and R shall be taken as 1.5.

$$\text{Mass of AAS} = \text{Mass of NaOH} (1.5 + 1)$$

$$\begin{aligned} \text{Mass of NaOH (M}_{\text{NaOH}}) &= \text{Mass of AAS} / 2.5 \\ &= 200 / 2.5 = 80 \text{ kg/m}^3 \end{aligned}$$

$$\begin{aligned} \text{Mass of Na}_2\text{SiO}_3 (\text{M}_{\text{Na}_2\text{SiO}_3}) &= 1.5 \times \text{M}_{\text{NaOH}} \\ &= 1.5 \times 80 = 120 \text{ kg/m}^3 \end{aligned}$$

### STEP 5: Calculation of Water Content in AAS

$$\begin{aligned} \text{Mass of water in NaOH} &= \text{M}_{\text{NaOH}} (1 - S_{\text{NaOH}}) \\ &= 80 (1 - 0.455) = 80 (0.545) = 43.6 \text{ kg/m}^3 \end{aligned}$$

$$\begin{aligned} \text{Mass of water in Na}_2\text{SiO}_3 &= \text{M}_{\text{Na}_2\text{SiO}_3} (1 - S_{\text{Na}_2\text{SiO}_3}) \\ &= 120 (1 - 0.345) \\ &= 120 (0.655) = 78.6 \text{ kg/m}^3 \end{aligned}$$

$$\begin{aligned} \text{Total Water Content (Wc) in the mix} &= \text{Mass of water in (NaOH} + \text{Na}_2\text{SiO}_3) \\ &= 43.6 + 78.6 = 122.2 \text{ kg/m}^3 \end{aligned}$$

$$\begin{aligned} \text{Total solid content} &= 500 + 36.4 + 41.4 \\ &= 577.8 \text{ kg/m}^3 \end{aligned}$$

$$\begin{aligned} \text{Water to geopolymer solid ratio} &= \text{Total water content} / \text{Total solid content} \\ &= 122.2 / 577.8 = 0.21 \end{aligned}$$

### STEP 6: Determination of Total Aggregates

The volume of total aggregates (VTA) is obtained by using the absolute volume method as follows:

$$\begin{aligned} \text{VTA} &= 0.98 - \left[ \left\{ \left( \frac{\text{Bc}}{\text{GB}} \right) + \left( \frac{\text{M}_{\text{NaOH}}}{\text{G}_{\text{NaOH}}} \right) + \left( \frac{\text{M}_{\text{Na}_2\text{SiO}_3}}{\text{G}_{\text{Na}_2\text{SiO}_3}} \right) \right\} \times \left\{ \frac{1}{1000} \right\} \right] \\ &= 0.98 - \left[ \left\{ \left( \frac{500}{2.2} \right) + \left( \frac{80}{1.4506} \right) + \left( \frac{120}{1.35} \right) \right\} \times \left\{ \frac{1}{1000} \right\} \right] \\ &= 0.98 - 0.371 = 0.609 \text{ m}^3 \end{aligned}$$

### STEP 7: Calculation of Fine and Coarse Aggregate Content

$$\begin{aligned} \text{Mass of fine aggregate (MFA)} &= (30\% \times \text{VA}) \times \text{GFA} \times 1000 \\ &= (20\% \times 0.654) \times 2.63 \times 1000 \\ &= 480.501 \text{ kg/m}^3 \end{aligned}$$

$$\begin{aligned} \text{Mass of 20mm aggregate (M20)} &= (33\% \times \text{VA}) \times \text{G20} \times 1000 \\ &= (28\% \times 0.654) \times 2.73 \times 1000 \\ &= 548.65 \text{ kg/m}^3 \end{aligned}$$

$$\begin{aligned} \text{Mass of 12.5mm aggregate (M12.5)} &= (32\% \times \text{VA}) \times \text{G12.5} \times 1000 \\ &= (37\% \times 0.654) \times 2.76 \times 1000 \\ &= 621.91 \text{ kg/m}^3 \end{aligned}$$

#### STEP 8: Superplasticizer (SP) Dosage

Based on the experimental observations in the laboratory, SP dosage of 1% of binder content is found to be suitable to improve the workability and the same has been followed in this case.

$$\text{SP Dosage} = 1\% \times 500 = 5 \text{ kg/m}^3$$

Binder	FA (Kg/m <sup>3</sup> )	CA (20 mm) (Kg/m <sup>3</sup> )	CA (12.5mm) (Kg/m <sup>3</sup> )	NaOH (Kg/m <sup>3</sup> )	Na <sub>2</sub> SiO <sub>3</sub> (Kg/m <sup>3</sup> )	Water	SP (Kg/m <sup>3</sup> )
500	480.5	548.65	621.9	36.4	41.4	122.2	5
1	0.961	1.097	1.244	0.073	0.083	0.25	0.01

### 8. Comparison between 10 M and 12 M (Molarity)

$$\text{Molarity} = 10\text{M}$$

$$\text{NaOH} = 10 \times 40 = 400$$

$$\text{Mass of NaOH (M}_{\text{NaOH}}) = 200/1000 \times 400 = 80 \text{ kg/m}^3$$

$$\begin{aligned} \text{Mass of Na}_2\text{SiO}_3 (\text{M}_{\text{Na}_2\text{SiO}_3}) &= 1.5 \times \text{M}_{\text{NaOH}} \\ &= 1.5 \times 80 = 120 \text{ kg/m}^3 \end{aligned}$$

$$\text{Molarity} = 12\text{M}$$

$$\text{NaOH} = 12 \times 40 = 480$$

$$\text{Mass of NaOH (M}_{\text{NaOH}}) = 200/1000 \times 480 = 96 \text{ kg/m}^3$$

$$\begin{aligned} \text{Mass of Na}_2\text{SiO}_3 (\text{M}_{\text{Na}_2\text{SiO}_3}) &= 2.5 \times \text{M}_{\text{NaOH}} \\ &= 2.5 \times 80 = 240 \text{ kg/m}^3 \end{aligned}$$

## 9. CONCLUSION

In this project, we have analysed and designed a durable sustainable bunker for storage purposes. Structural elements like beams, columns, vertical slabs, and footing. are designed by the limit state method. It provides better thermal insulation properties. The structure was durable and sustainable (resistance against chemical attack). Also, it makes economical and eco-friendly concrete. We have also done the analysis of various load combinations as per the Indian Standard Code of Practice and estimation, costing as per the schedule of rates.

### 10. ACKNOWLEDGEMENT

We kindly acknowledge the facilities provided by Easwari Engineering college to complete this research work through DRDO-funded equipment and AICTE MODROB-funded equipments for testing and other experimental works. The authors wish to thank the Department of Science & Technology, Government of India, for funding the research infrastructure under the scheme entitled “ Funds for the improvement of S&T Infrastructure (DST-FIST)” Ref.NO.SR/FST/college -2017/110(c).

### REFERENCE

- [1] LAVANYA PRABHA, S., GOPALAKRISHNAN, M., NEELAMEGAM, M., :  
Development of high-strength nano-cementitious composites using copper slag, ACI

---

Materials Journal, 117(4), 37–46 (2020).

- [2] S. LAVANAYA PRABHA, A. MOHAN, G. VELRAJKUMAR, A. MOHAMMEDHAROONZUBAIR., Study On Structural Behaviour Of Ductile High-Performance Concrete Under Impact And Penetration Loads ., Journal of Environmental Protection and Ecology 23, No 6, 2380–2388 (2022)
- [3] MOHAN, A , VIJAYAN, D.S. ,REVATHY, J., PARTHIBAN, D., VARATHARAJAN, R. :Evaluation of the impact of thermal performance on various building bricks and blocks: A review, Environmental Technology and Innovation, 23, 101577 (2021).
- [4] M. THOLKAPIYAN, A.MOHAN, VIJAYAN.D.S. :A survey of recent studies on chlorophyll variation in Indian coastal waters, IOP Conf. Series: Materials Science and Engineering 993 , 012041, 1-6 (2020).
- [5] GOPALAKRISHNAN, R., MOHAN, A., SANKAR, L. P., & VIJAYAN, D. S. : Characterisation On Toughness Property Of Self-Compacting Fibre Reinforced Concrete. In Journal of Environmental Protection and Ecology , 21(6), 2153–2163.
- [6] M. THOLKAPIYAN , A. MOHAN, D. S. VIJAYAN.,VARIABILITY OF SEA SURFACE TEMPERATURE IN COASTAL WATERS OF GULF OF MANNER, INDIA, Oxidation Communications 45, No 3, 562–569 (2022) .
- [7] MOHAN, A., TABISH HAYAT, M. :Characterization of mechanical properties by preferential supplant of cement with GGBS and silica fume in concrete, Materials Today: Proceedings, 43, 1179–1189 (2020).
- [8] DHARMAR, S., GOPALAKRISHNAN, R., MOHAN, A. :Environmental effect of denitrification of structural glass by coating TiO<sub>2</sub>, Materials Today: Proceedings, 45, 6454–6458 (2020).
- [9] MOHAN, A., PRABHA, G., BALAPRIYA, B., DEEPIKA, M., HEMANTHIMEKALA, B. Tribological Investigations on the Properties of Concrete Containing Recycled Plastic Aggregate, Journal of Balkan Tribological Association, 27(6), pp. 1010–1020 (2021).
- [10] AYYASAMY, L.R., MOHAN, A., REX, L.K., ...VIJAYAN, D.S.: Enhanced Thermal Characteristics Of Cuo Embedded Lauric Acid Phase Change Material, Thermal Science, 26(2), pp. 1615–1621 (2022).
- [11] THOLKAPIYAN, M., MOHAN, A., VIJAYAN, D.S.:Tracking The Chlorophyll

---

Changes Using Sentinel-2A/B Over The Gulf Of Manner, India, *Oxidation Communications*, 45(1), pp. 93–102 (2022).

- [12] Dr.G.VELRAJKUMAR, R.MURALIKRISHNAN, A.MOHAN, R.BALATHIRUMAL, P.NAVEEN JOHN: Performance of GGBFS and silica fume on self compacting geopolymer concrete using partial replacements of R-Sand, *materials today : proceedings*, Volume 59, Part 1, Pages 909-917 (2022).
- [13] D. S. VIJAYAN , A. MOHAN , C. NIVETHA , VIDHYALAKSHMI SIVAKUMAR ,PARTHIBAN DEVARAJAN , A. PAULMAKESH , AND S. ARVINDAN: Treatment of Pharma Effluent using Anaerobic Packed Bed Reactor, *Journal of Environmental and Public Health*, Volume 2022, Article ID 4657628, 6 pages (2022).
- [14] AYYASAMY, L.R., MOHAN, A., VIJAYAN, D.S., ...DEVARAJAN, P., SIVASURIYAN, A.: Finite element analysis of behavior and ultimate strength of composite column ,*Science and Engineering of Composite Materials*, 29(1), pp. 176–182, (2022).
- [15] GOPALAKRISHNAN, R., MOHAN, A., SANKAR, L. P., & VIJAYAN, D. S , Characterisation of Toughness Property of Self-Compacting Fibre Reinforced Concrete. In *Journal of Environmental Protection and Ecology* 21(6) 2153 (2020)
- [16] MOHAN, A., SARAVANAN, J., Characterization Of Geopolymer Concrete By Partial Replacement Of Construction And Demolition Waste – A Review., *Journal of the Balkan Tribological Association*, 2022, 28(4), pp. 550–558.
- [17] SRIVIDHYA K , MOHAN A, THOLKAPIYAN M, ARUNRAJ A, “Earth Quake Mitigation (EQDM) Through Engineering Design”, *Materials Today : Proceedings*, Volume 22, 1074-1077, (2020).
- [18] MOHAN, A, Experimental Investigation on the Ecofriendly External Wrapping of Glass Fiber Reinforced Polymer in Concrete Columns, *Advances in Materials Science and Engineering*, Volume 2021, Article ID 2909033, 12 pages .
- [19] KARTHIKA, V.S. , MOHAN, A. , KUMAR, R.D. , JAMES, Sustainable consideration by characterization of concrete through partial replacement of fine aggregate using granite powder and iron powder, *Journal of Green Engineering*, 9 (4), 514-525, 2020.
- [20] A JOTHILAKSHMI, M. , CHANDRAKANTHAMMA, L. , DHAYA CHANDHRAN, K.S. , MOHAN Flood control and water management at basin level-at orathur of Kanchipuram district *International Journal of Engineering and Advanced*



---

Technology, 2019, 8 , International Journal of Engineering and Advanced Technology  
8 (6), 1418-1421

- [21] THOLKAPIYAN, M., MOHAN, A., VIJAYAN, D.S., TRACKING THE CHLOROPHYLL CHANGES USING SENTINEL-2A/B OVER THE GULF OF MANNER, INDIA, Oxidation Communications, 2022, 45(1), pp. 93–102.
- [22] A MOHAN, K. S. DHAYA CHANDHRAN, M. JOTHILAKSHMI, L. CHANDHRKANTHAMMA, Thermal Insulation and R- Value Analysis for Wall Insulated with PCM, International Journal of Innovative Technology and Exploring Engineering volume 12 S, 912-921, 2019.
- [23] THOLKAPIYAN, M., MOHAN, A., VIJAYAN, D.S. Spatial And Temporal Changes Of Sea Surface Phytoplankton Pigment Concentration Over Gulf Of Manner, India Oxidation Communications, 2021, 44(4), pp. 790–799
- [24] VELRAJKUMAR, G., MUTHURAJ, MP., Effect of position of hexagonal opening in concrete encased steel castellated beams under flexural loading”, Computers and Concrete, 2020, 26(1), pp. 95-106.