



# A NEW METHOD FOR THE SYNTHESIS OF NANOPARTICLES FOR BIOMEDICAL APPLICATIONS

Sh. Kekutia,<sup>[a]\*</sup> L. Saneblidze,<sup>[a]</sup> V. Mikelashvili,<sup>[a]</sup> J. Markhulia,<sup>[a]</sup> R. Tatarashvili,<sup>[a]</sup> D. Daraselia,<sup>[b]</sup> and D. Japaridze<sup>[b]</sup>

Presented at 3rd International Conference “Nanotechnologies”, October 20 – 24, 2014, Tbilisi, Georgia (Nano – 2014)

**Keywords:** Nanoparticles, iron oxides, electrohydraulic technique, ascorbic acid, biomedical applications.

New chemical synthesis methods for producing nano-sized iron oxides particles and producing biocompatible polymer coated nanoparticles in the solution has been investigated. A new particle processing device for making high performance nanomaterials as well as their applications in medicine has been developed by applying electrohydraulic technique for nanohomogenization. Biomedical application requires the biocompatible super paramagnetic iron oxide nanoparticles (SPIONs), which are stable and well dispersed in water at physiological pH or in physiological salinity. In order to obtain biocompatible SPIONs, particles of 10-15 nm size have been synthesized and these SPIONs have been coated with ascorbic acid. Vibrating Sample Magnetometer studies (VSM) were carried out to study the effect of phase transformations on the magnetic properties of the nanoparticles. The samples were analyzed by VSM at room temperatures to find the saturation magnetization. The ascorbic acid coated iron oxide nanoparticles were found to be well dispersed in water as they have a hydrophilic outer surface containing hydroxyl and amine groups. This hydrophilic outer surface is likely to enhance their bioactivity. Therefore they may become a very good drug carrier for biomedical applications.

\* Corresponding Authors

E-Mail: [kekuka@yahoo.com](mailto:kekuka@yahoo.com), [vmikelashvili@gmail.com](mailto:vmikelashvili@gmail.com)

[a] V. Chavchanidze Institute of Cybernetics of the Georgian Technical University, Sandro Euli Str. 5, Tbilisi 0186, Georgia

[b] I. Javakhishvili Tbilisi State University, Department of Physics, I.Chavchavadze Ave. 3, 0179 Tbilisi, Georgia

(Fe<sub>3</sub>O<sub>4</sub>) and maghemite (γ-Fe<sub>2</sub>O<sub>3</sub>) are the very promising reagents since their biocompatibility has already been proven.<sup>2</sup>

It is a technological challenge to control size, shape, stability, and dispersibility of MNPs in desired solvents. Iron oxide MNPs have a large surface-to-volume ratio and therefore possess high surface energies. Consequently, they tend to aggregate so as to minimize the surface energies. Moreover, the naked iron oxide NPs have high chemical activity, and are easily oxidized in air (especially magnetite), generally resulting in loss of magnetism and dispersibility. Therefore, providing proper surface coating and developing some effective protection strategies to stabilize iron oxide MNPs is very important and that was the aim of the present work. In general, these strategies comprise grafting of or coating the particles with organic molecules, including small organic molecules or surfactants, polymers, and biomolecules, or coating with an inorganic layer, such as silica, metal or nonmetal elementary substance, metal oxide or metal sulfide. It is worth noting that in many cases the protecting shells not only stabilize the NPs, but can also be used for further functionalization.<sup>3</sup>

The most conventional method for obtaining Fe<sub>3</sub>O<sub>4</sub> or γ-Fe<sub>2</sub>O<sub>3</sub> is by co-precipitation.<sup>4</sup> The size and shape of the iron oxide NPs depends on the type of salt used (such as chlorides, sulfates, nitrates, perchlorates, etc.), the ferric and ferrous ions ratio, the reaction temperature, the pH value, ionic strength of the media, and the other reaction parameters (e.g. stirring rate, rate of addition of basic solution).

But this method needs to be improved in order to cause mono dispersity, which is necessary for biomedical applications. To achieve this, we for the first time used the electrohydraulic treatment (Yutkin treatment) in a well-known scheme for the synthesis of nanoparticles in order to significantly reduce the radius scatter of particles.<sup>5,6</sup>

## Introduction

Magnetic nanofluids or nanoferrofluids refer to the stable colloidal suspensions of magnetic nanoparticles (MNPs) in a carrier liquid. Usually, the MNPs have core-shell structures in which the cores are made of magnetic crystallites and the shells are made of organic or inorganic substances. For most nanoferrofluids, the size of magnetic cores is in the range of several nanometers to tens of nanometers, containing only a simple magnetic domain. Owing to their extremely small size, the MNPs exhibit super paramagnetic behavior. This means that the MNPs are magnetically responsive but remain nonmagnetic in absence of the magnetic field. The colloidal MNPs can be readily dispersed in a liquid to form a nanoferrofluid.

MNPs are used in important biological applications, including magnetic bioseparation, detection of biological entities (cell, protein, nucleic acids, enzyme, bacteria, virus, etc.), clinic diagnosis and therapy (such as magnetic resonance image), magnetic fluid hyperthermia (MFH), targeted drug delivery and biological labels. In general, it is crucial to choose the materials for the construction of nanostructure materials and devices with adjustable physical and chemical properties. On this basis, iron oxide MNPs are the strong candidates for such devices, and the application of iron oxide MNPs in in vitro diagnostics has been in practice for nearly half a century.<sup>1</sup> In the last decade, investigations with several types of iron oxides have been carried out in the field of MNPs, among which magnetite

The proposed approach, as shown by preliminary studies, significantly improves the dispersion of solution. Strong oscillations associated with electrohydraulic technique, additionally produce resonant treatment of chemically synthesized particles. The process involves a series of controlled explosions produced by electro impulse discharges at the high voltage (electro sparks) in liquid. The discharges generate massive shock waves and impulses of pressure that create homogenization action on nanoparticles. As a result, radii of the particles become almost same and the particle solubility in water is increased.

Hence, in this study, we have focussed mainly on the development of various strategies for the preparation, structure determination and magnetic properties of various surface functionalized iron oxide MNPs and their applications. The properties of functionalized iron oxide nanoparticles, synthesized via chemical method and electrohydraulic technique have been compared.

We have carried out preparation of the magnetic colloid by a modified co-precipitation method along with electrohydraulic treatment, with further magnetite stabilization. The samples are analyzed by VSM at room temperature to find the saturation magnetization of ascorbic acid coated iron oxide NPs.

## Experimentals

### Synthesis of Magnetic Nanoparticles

We have synthesized magnetite nanoparticles by chemical precipitation of mixed iron(III) chloride hexahydrate ( $\text{FeCl}_3 \cdot 6\text{H}_2\text{O}$ ) and iron(II) chloride tetrahydrate ( $\text{FeCl}_2 \cdot 4\text{H}_2\text{O}$ ) or iron(II) sulfate heptahydrate ( $\text{FeSO}_4 \cdot 7\text{H}_2\text{O}$ ) with iron ions in 2:1 molar ratio, with in NaOH or  $\text{NH}_4\text{OH}$  solution at room or relatively high temperature ( $80^\circ\text{C}$ ) and in air or under a flow of nitrogen. Chemical co-precipitation consists of two processes, nucleation i.e. formation of centres of crystallization and subsequent growth of particles.

The co-precipitation process was carried out by Massart's procedure,<sup>4</sup> which involves drop wise addition of NaOH solution into the mixture of the aqueous solutions of iron salts, at either the room temperature or  $80^\circ\text{C}$  under continuous vigorous magnetic or mechanical stirring. The reactions can be represented as follows.

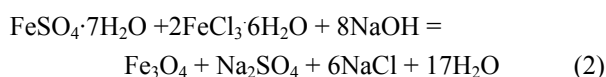
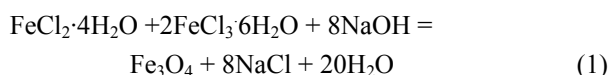

The solution turned from brown to black indicating the formation of magnetite ( $\text{Fe}_3\text{O}_4$ ). The solution was subjected to magnetic stirring for 60 min to ensure nucleation and growth of magnetite particles. On the completion of the precipitation process, the separation of two phases was observed, a solid phase and a supernatant liquid. The black

solid phase was magnetically decanted (while the supernatant was carefully removed) and was repeatedly washed with deionized water in order to ensure the elimination of residual salts. The precipitate was further washed with ethanol to remove traces of water and was subsequently heated for some minutes to ensure evaporation of ethanol. The ready magnetic nanofluid was then subjected to electrohydraulic treatment for about 1 h to yield finally the highly dispersed magnetic nanofluid. After electrohydraulic treatment the black precipitates were again washed with deionized water. At last 10% of ascorbic acid from weight of nanoparticles was added into the mixture to modify the  $\text{Fe}_3\text{O}_4$  magnetic nanoparticles and the mixture was heated to  $80^\circ\text{C}$  under magnetic stirring. After 1 h of modification, the resulting  $\text{Fe}_3\text{O}_4$  magnetic nanoparticles (black precipitate) were collected from the solution by magnetic separation and washed several times with deionized water and ethanol. The pH was adjusted to 8 in order to simulate a biological environment. Two hours of sonication were required to obtain well dispersed nanoparticles. The nanoparticle solutions were then left at room temperature.

During synthesis of nanofluids, attention is required to be paid to the size of the nanoparticles. The dimensions should be homogeneous with little departure from the average size. The existing methods of synthesis do not provide an acceptable quality in this respect. To ensure high quality, we turned to the electrohydraulic technique. To achieve this, we created a device, which is presently a stationary pilot equipment. The electrohydraulic technique was used during one of the stages of synthesis of magnetic nanofluid. By using the device created by us, it is possible to homogenize a nanofluid and therefore to have highly dispersed magnetic nanofluid. The scheme of the electrohydraulic device is shown in Figure 1.

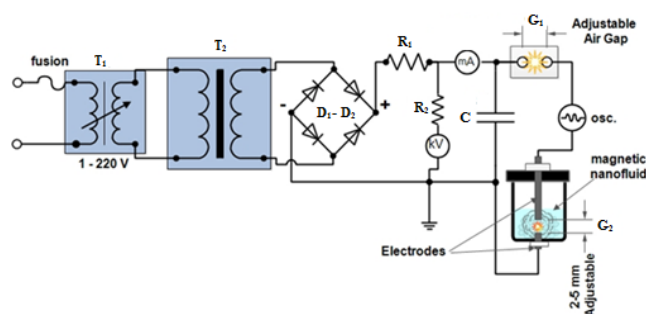

**Figure 1.** A schematic diagram of the electrohydraulic device. The device has a power supply, transformer ( $T_1, T_2$ ), charger resistance ( $R_1, R_2$ ), storage capacitor ( $C$ ), electrodes with adjustable air gap for creating a spark ( $G_1$ ), and submerged electrodes with adjustable air gap for creating a spark ( $G_2$ ).

The magnetic properties of the polymer-coated magnetite nanoparticles were measured in water solution state at room temperature using a Standard 7300 Series Lake Shore Cryotronics vibrating sample magnetometer (Criogenic Ltd, UK). The hysteresis loop of each sample was measured over a range of applied fields from  $-3$  to  $+3$  T with a resolution of  $10^{-4}$  emu.

## Results and Discussion

VSM was used to evaluate magnetization of the MNPs as a function of an applied external magnetic field ( $H$ ) between  $-3$  and  $3$  Tesla. Based on the obtained VSM curve at room temperature, magnetic behaviours of the MNPs can be analyzed. For example, at room temperature, the zero magnetic remanence (when  $H$  is zero), and the hysteretic loop feature indicates that the MNPs are super paramagnetic. Also, from the plateau part of the VSM curve, saturation magnetization can be determined. The dependences of magnetic momentum of MNPs on magnetic field are shown in Figures 2-5.

The Fig. 2 presents the dependence of the magnetic moments of magnetic nanofluid on the applied external magnetic field at room temperature for bare magnetic nanoparticles synthesized by chemical co-precipitation method and in Figure 3 the same dependence, only the nanoparticles were additionally treated by electrohydraulic technique.

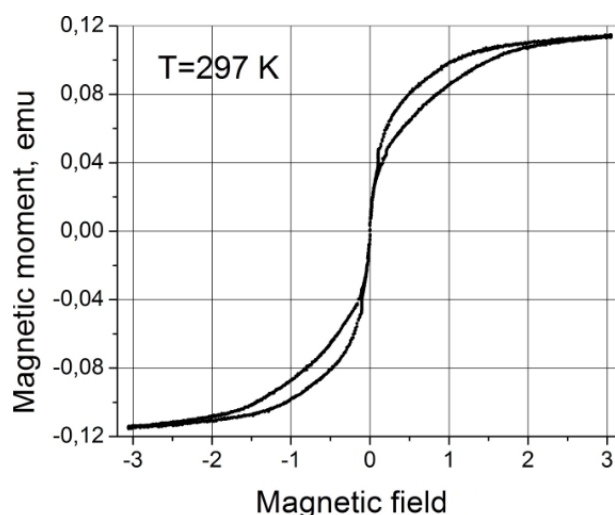

**Figure 2.** The dependence of magnetic moment of bare MNPs on magnetic field.

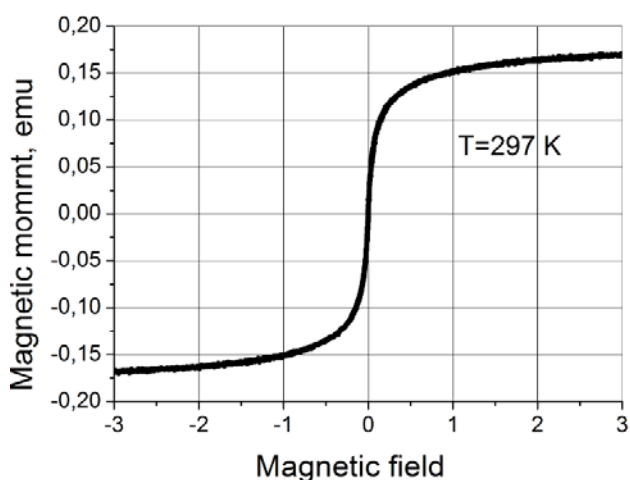

**Figure 3.** The dependence of magnetic moment of electrohydraulically treated bare MNPs on magnetic field

Figures clearly indicate the super paramagnetic nature of the produced nanomaterials. Also from these figures, we can conclude that the electrohydraulic treatment significantly improves the magnetic properties of nano materials and the magnetic particles are more dispersed.

Figure 4 presents the dependence of the moments of ascorbic acid-coated magnetic nanoparticles on applied external magnetic field, the same dependence is shown in Figure 5, when the magnetic nanoparticles were treated by electrohydraulic device before the coating. Ascorbic acid coated magnetic nanoparticle formulation and its therapeutic uses have recently been introduced. Hydrophilic ascorbic acid derivatives such as ascorbyl glycoside have been used not only as antioxidants, as food and pharmaceutical excipients but also as stabilizer.

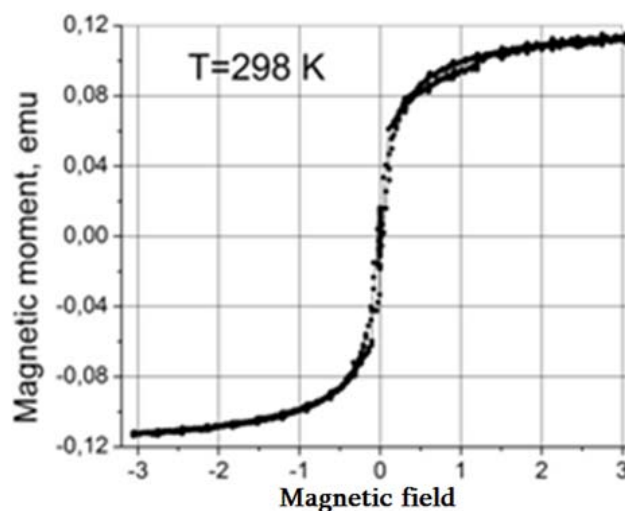

**Figure 4.** The dependence of the magnetic moment of ascorbic acid coated MNPs on magnetic field.

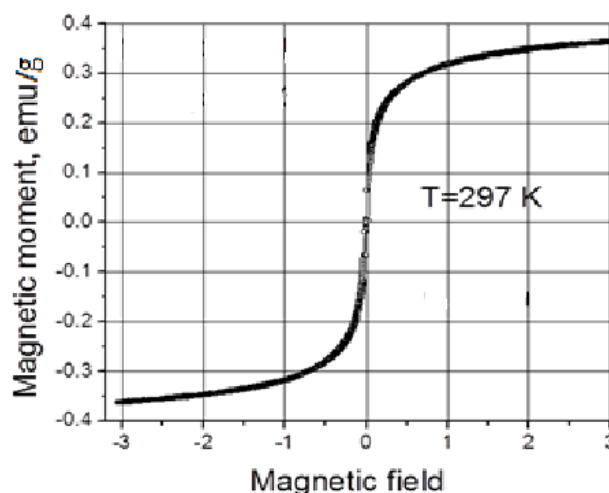

**Figure 5.** The dependence of the magnetic moment of ascorbic acid coated and electrohydraulic treated MNPs on magnetic field.

Nanoparticle technology is being incorporated into many areas of molecular science and biomedicine. Because nanoparticles are small enough to enter almost all areas of

the body, including the circulatory system and cells, they have been and continue to be exploited for basic biomedical research as well as clinical diagnostic and therapeutic applications. To study the coating mechanism, it is very helpful to work with particles that are uniform in size and shape.

The main advantage of the precipitation process is that a large amount of nanoparticles can be synthesized. However, the control of particle size distribution is limited, because only kinetic factors are controlling the growth of the crystal. To avoid this drawback we utilize the electrohydraulic phenomenon.

To make the best use of nanoparticles and solve the problems of their applications, the development of nanomaterial processing techniques is essential. New synthesis methods for producing nano-sized oxides particles and producing biocompatible nano-composite particles in the solution phase have been reported in this article. In addition, electrohydraulic treatment method (e.g. homogenization) is briefly discussed.

This research work aims to solve the aggregation problem, eventually leading to a cheap, effective, and safe nanoparticle-necessary for cancer treatment. Magnetite ( $\text{Fe}_3\text{O}_4$ ) is also less toxic to organic systems. The loop shows a significant increase in magnetic moment for electrohydraulic treated nanoparticles as compared to those without this treatment. Synthesized magnetite,  $\text{Fe}_3\text{O}_4$ , is a powerful magnetic vector for penetration into the tumor. For biomedical applications such as MRI, drug-delivery and hyperthermia, the nanoparticles have to be biocompatible, have a large enough moment for targeting and display super paramagnetic behavior.

Presented figures show the magnetization curve as a function of magnetic field for the uncoated and coated nanoparticles. From the figures, no hysteresis curve was observed, which indicates the characteristic super paramagnetic behavior of the nanoparticles. The magnetic moment values of the MNPs were found between 0.120 and 0.175 emu, depending from their treatment method (with or without electrohydraulic treatment).

In addition, the magnetization decreases from the plateau value and reaches zero when the magnetic field is removed. The behavior shows that the iron oxide nanoparticles correspond to the single-crystal domain exhibiting only one orientation of the magnetic moment and are magnetite in structure.

So, it was found from VSM studies that the magnetic nanoparticles show no diamagnetic contribution and are small enough to exhibit super paramagnetic behaviour, thus, they are of particular interest for drug targeting systems, as they do not retain any magnetism after removal of a magnetic field.

## Acknowledgments

The authors acknowledge the funding from Shota Rustaveli National Science Foundation (Grant No. AR/96/3-250/13).

## References

- <sup>1</sup>Krishanan, K. M., *IEEE Trans. Magn.*, **2010**, *46*, 2523-2558.
- <sup>2</sup>Laurent, S., Forge, D., Port, M., Roch, A., Robic, C., vander Elst, L., Muller, R. N., *Chem. Rev.*, **2008**, *108*, 2064-2110.
- <sup>3</sup>Veiseh, O., Gunn, J. W., Zhang, M., *Adv. Drug Delivery Rev.*, **2010**, *62*, 284-304.
- <sup>4</sup>Massart, R., *IEEE Trans. Magn.*, **1981**, *17*, 1247-1248.
- <sup>5</sup>Yutkin, L. A., *Electrohydraulic Effect and Its Application in Industry* (in Russian), Mashinostroenie, Leningrad, **1986**.
- <sup>6</sup>Mikelashvili, V., Markhulia, J., Kekutia, Sh., Tatarashvili, R., *2nd Int. Conf. "Nanotechnologies" (Nano - 2012)*, Tbilisi, **2012**, 30-37.

Received: 29.12.2014.

Accepted: 28.01.2015.