



ENERGY EMISSIONS OF SPARK DISCHARGE UNDER WATER

Tomasz Izdebski^{[a]*}, Mirosław Dors^[a], Jerzy Mizeraczyk^[a,b]*Presented at Fifth Central European Symposium on Plasma Chemistry (Budapest, 2013. augustus 25-29.)***Keywords:** spark discharge, electrohydraulic discharge, energy emission.

The recent focus of research with electrohydraulic discharges is on bacteria and microorganism inactivation. The processes and main biocidal effects in which this occurs are not fully understood. In this paper a study of energy emission from electrohydraulic spark discharge is presented. The spark discharge was generated in a cylindrical reactor 25 mm in diameter made of PTFE between a stainless steel hollow needle electrode and a steel rod electrode. Distilled water was used and the flow was 30 ml/min. The gap between the electrodes was 3 mm. Spark discharge energy was measured to be 1.2-1.4 J. Measurements show that over 50% of this energy is used for heating of the reactor and electrodes, and about 2% for acoustic waves. The rest of the discharge energy, i.e. ~0.54 J, is distributed among UV/Vis radiation, production of primary active species and ultrasonic.

* Corresponding author

E-Mail: tizdebski@imp.gda.pl

- [a] Centre for Plasma and Laser Engineering, The Szewalski
Institute of Fluid Flow Machinery, Gdańsk, Poland
[b] Department of Marine Electronics, Gdynia Maritime
University, Gdynia, Poland

Introduction

Generation of plasmas in liquids has been studied extensively in the past for various applications, e.g. insulation and high power switching¹, removal of organic contaminants¹⁻⁵ and water sterilization.²⁻³ A lot of research in physics and chemistry of such discharges was made and still we don't know much about them. There is no consensus over plasma formation mechanism and all the more on biocidal effects leading to sterilization. It is generally accepted that the main energy emissions from spark discharges are heat emission, UV/Vis radiation, shock wave formation, and energy used for chemical reactions and formation of active species.^{2,6} The primary chemical reactions inside water originated from plasma result in the formation of chemically active species (e.g. OH•, H•, O•, HO₂•) which either recombine to form stable by-products such as H₂O₂ and H₂, or they return to a lower energetic state and emit UV light.⁷⁻¹⁰

However, in the presence of impurities (organic and inorganic compounds), primary and secondary molecular, ionic, or radical species produced by the discharge can attack these molecules and cause their degradation. Alternatively, these impurities can be degraded indirectly through pyrolysis in the vicinity of high voltage electrode or photolysis.

In the electrohydraulic discharge like spark, the generation of active species follows the formation and propagation of the plasma channel. Researchers have shown that as the plasma channel expands throughout the surrounding liquid it forms shock wave, induces cavitations and emits UV light.^{2,10}

While studies on chemical effects of the shock wave-induced cavitations and UV light are scarce, the biological effects of shockwaves on the soft animal tissue are currently under full investigation.¹¹⁻¹² Establishing the effects of chemical species, shock wave and UV light on the degradation of molecules in the bulk phase is extremely important to understand their role in the sterilization of water. To fully understand which of these effects of spark discharge has the main influence on bacteria and microorganism inactivation, first we need to understand the distribution in so called electrohydraulic discharge.

Experimental set-up

Cylindrical reactor made of PTFE was 6 cm in height and had a diameter of 25 mm. The material was chosen to be the least chemically active and capable of withstanding high pressure waves from the spark discharge. A quartz window was inserted in the side of the reactor for UV/Vis emission spectra analysis.

A pulsed positive discharge was generated between a high voltage stainless steel hollow needle electrode and a grounded steel rod electrode (5 mm in diameter), both immersed in the water. The inner and outer diameter of the hollow needle were 1.4 mm and 1.6 mm, respectively. The discharge was generated at the edge of the hollow needle, whereas the rest of the needle was covered with an insulator. Spark discharge was generated when the needle-rod spacing was 3 mm. A technical scheme of reactor configuration and power supply is presented in figure 1. A voltage of 16 kV was applied to the needle electrode with a frequency of 50 Hz. Positive high voltage pulses were applied to the hollow needle electrode from a discharge capacitor C1 (2 nF). The capacitor was charged from a DC power supply through a resistor R (10 kΩ) and a capacitor C2 (22 nF). The pulse repetition rate of 50 Hz was fixed by the rotation velocity of a rotating spark gap switch. The amplitudes of the voltage and current corona pulses were measured using a TEKTRONIX P6015A high voltage probe and a PEARSON 2878 current monitor (Rogowski coil), respectively.

The waveforms were observed and recorded on a TEKTRONIX TDS 3052B oscilloscope. Pulse discharge energy was between 1.2 and 1.4 J. Typical voltage and current pulses are presented in Figure 2.

The acoustic energy measurements were carried out in a 30 cm distance from the source with a certified acoustic meter SVAN 945 which measures the sound intensity in a frequency range from 1 Hz to 20 kHz. Temperature and relative humidity of the ambient air were 22 °C and 20%.

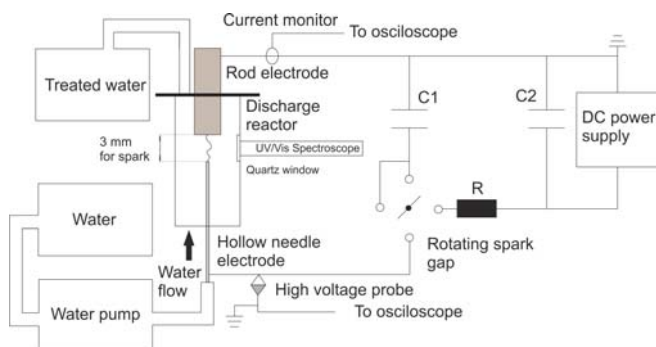

Figure 1. Experimental set-up scheme of spark discharge reactor and power supply. C1 = 2 nF, C2 = 22 nF, R = 10 kΩ

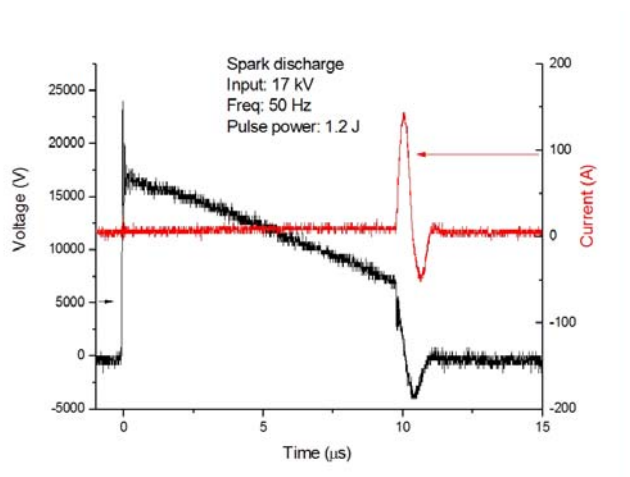

Figure 2. Typical voltage and current pulse of the spark electrohydraulic discharge

The UV radiation emission spectroscopy was performed using Maya2000 spectrometer equipped with a UV/Vis transmittable optical fibre with optical resolution (FWHM) of 0.5 nm. Acquisition was done 5 cm from the discharge through a quartz window.

Water volume in the reactor was 26 ml. The water was flowing once through the reactor chamber with a flow rate of 30 ml/min. Conductivity was adjusted with NaCl to 300 μS in order to be similar to river water which was the subject of our previous studies.

Temperature of the water was measured using thermocouple placed inside the reactor immediately after the discharge was turned off.

Results

The distribution of energy emitted during the spark discharge in water can be described by the balance:

Energy delivered to the spark discharge = Energy emitted from the plasma.

Since we are not able to measure each and every form of the energy emitted by the plasma separately such as ultrasound and UV/Vis radiation we assume that equation (1) has a form:

$$E_p = E_{aq} + E_{us} + E_{UV} + E_{th} + E_{ch} \quad (1)$$

where

- E_p – input energy,
- E_{aq} – acoustic energy,
- E_{us} – ultrasonic energy,
- E_{UV} – UV/Vis emission energy,
- E_{th} – thermal Energy,
- E_{ch} – energy spent on chemical reactions (ionization, dissociation and excitation).

The energy E_p delivered by the spark discharge to the water was calculated from the current and voltage pulses presented in Figure 2 using standard equation:

$$E_p = \int U(t)I(t)dt \quad (2)$$

The E_p value varies in our reactor in the range of 1.2 to 1.4 J.

As for the forms of energy emitted from the spark discharge they are described below. It is worthy of noting that in some works theoretical computations of several energies associated with spark discharges are given.¹³⁻¹⁴ However, it seems that in these computations several parameters can be set rather arbitrarily to obtain the desired result.

UV/Vis light emission

Emission spectra observed in the range of 200-1100 nm during the spark discharge is shown in figure 3. The spectra includes a strong continuous band from 200 to 1000 nm which is typical for highly heated solids (black body radiation). This is an evidence that local temperature in the plasma region is very high. Unfortunately, because of the continuous spectra it was not possible to determine the temperature of the plasma. It is also seen that OH, O and H species are formed but other peaks that appear in the emission spectra could not be identified. The spectra observed was similar to that of Sun et al.¹⁵

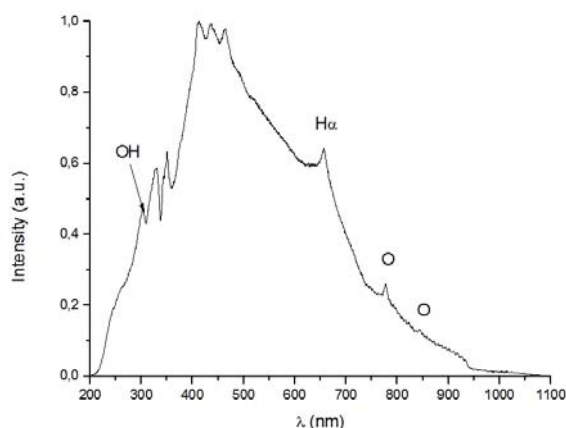

Figure 3. UV/Vis emission spectra of spark discharge in water

It must be pointed out that UV light recorded by the spectrometer is not the same as produced by the plasma. Part of it is absorbed by the water and transformed into heat and consumed in chemical reactions. Determination of exact amount of UV energy produced by the spark discharge is difficult. Many researchers use emission spectroscopy as a tool for the characterization of underwater discharges but they present only evolution of active species produced in the plasma and estimation of rotational/vibrational temperatures and electron densities in the plasma region. To our knowledge there is no literature showing that spectra emitted by the underwater discharge can be used to estimate quantity of discharge energy transferred into UV/Vis light. Therefore, we can only estimate UV energy in conjunction with other forms of energy which we cannot measure separately.

Acoustic energy emission

The frequency distribution of sound intensity generated by the electrohydraulic discharge reactor at 30 cm distance is presented in table 1. For this close proximity from the source we can omit the ambient air attenuation. We assume the spherical emission of the source. For the power calculations the sound intensities were integrated over the frequency spectra. The power of acoustic source is:

$$P = \frac{I}{e^{-mr}} 4\pi r^2 = 1.43 \text{ W} \quad (3)$$

where:

- r – distance from the discharge,
- I – sound intensity,
- m – sound absorption coefficient of air.

Acoustic power converted to a one pulse energy is $E_{ac} = 0.028 \text{ J}$. The ratio of estimated energy absorbed by the water to the electrical energy delivered to the spark discharge is then 2.0-2.3 %. This value is reasonable when comparing to results obtained by Buogo et al.¹⁶ They also studied the underwater spark discharge and found that 1.4-5.6 % of available energy was transferred into the acoustic energy.

Table 1. Frequency distribution of sound intensity levels

Frequency, Hz	Sound intensity level, dB	Sound intensity, W m^{-2}
1	25.9	$3.89 \cdot 10^{-10}$
2	38.5	$7.07 \cdot 10^{-9}$
4	49.8	$9.55 \cdot 10^{-8}$
8	52.2	$1.66 \cdot 10^{-7}$
16	51.0	$1.25 \cdot 10^{-7}$
31.5	51.0	$1.25 \cdot 10^{-7}$
63	48.0	$6.31 \cdot 10^{-8}$
125	50.4	$1.09 \cdot 10^{-7}$
250	48.0	$6.31 \cdot 10^{-8}$
500	50.9	$1.23 \cdot 10^{-7}$
1000	57.1	$5.12 \cdot 10^{-7}$
2000	74.8	$3.02 \cdot 10^{-5}$
4000	79.5	$8.91 \cdot 10^{-5}$
8000	80.4	$1.09 \cdot 10^{-4}$
16000	78.2	$66.0 \cdot 10^{-5}$

It is known from literature that the underwater spark discharges produces strong ultrasounds.¹⁷ Unfortunately, we are not able to measure this form of energy and we can only assume that it is a part of unaccountable energy together with UV radiation and energy spent on ionization, dissociation and excitation of molecules in the plasma region.

Thermal energy emission

Measuring the water temperature just after switching off the power supply shows that during 30 s of pulsed spark operation the temperature increases from 13.5 °C to 21.5 °C. As was shown by Foster et al. during the underwater plasma generation the temperature rise is rapid and essentially linear.¹⁸ Therefore, in our experiment measuring initial and final temperatures without intermediate points is justified. The calculation should yield a reasonable estimate of power deposited into the water. The energy absorbed by the water is simply calculated from the Joule's law:

$$Q = c \cdot m \cdot (T_k - T_p) \quad (4)$$

where

- c – specific heat of the medium,
- m – mass of the medium,
- T_p – initial temperature,
- T_k – final temperature.

For the thermal energy emission measurement data was as follows: water mass: 26 mL = 26 g, specific heat of water: 4187 J kg K⁻¹ = 1 kcal kg K⁻¹, specific heat of steel electrode: 300 J kg K⁻¹, mass of the electrodes: 4.2 g, time: 30 s.

Amount of thermal energy emission from equation (3) is $Q = 1097 \text{ J}$. It means that during one spark discharge pulse about $E_{th} = 0.73 \text{ J}$ was emitted as thermal energy. The ratio

of estimated energy absorbed by the water to the electrical energy delivered to the spark discharge is then 52-61 %. This value is reasonable when comparing to 63 % obtained by Foster et al.¹⁸

Conclusions

Spark discharge pulse was measured to be 1.2 to 1.4 J. Results of measurements show that 0.73 J, which is more than 50% of energy delivered to the spark discharge, is spent for water heating. Acoustic energy emission is 0.028 J which is comparable to loud speaking. Therefore, the rest of the discharge energy, i.e. ~0.54 J, is distributed among UV/Vis radiation and chemical reactions and ultrasonic waves in the reactor.

Acknowledgement

This research work was supported by the European Social Fund, the State Budget and the Pomorskie Voivodeship Budget according to the Operational Programme Human Capital, Priority VIII, Action 8.2, Under-action 8.2.2: 'Regional Innovation Strategy' within the system project of the Pomorskie Voivodeship "InnoDoktorant – Scholarships for PhD students, Vth edition" and by the National Center of Science according to decision number DEC-2011/01/N/ST8/05300.

References

- ¹Malik, M. A., Ghaffar, A., Malik, S. A., *Plasma Sources Sci. Technol.*, **2011**, *10*, 82.
²Sunka, P., *Phys. Plasmas*, **2001**, *8*, 2587.

- ³Yang, Y., Fridman, A., Cho, Y., *Adv. Heat Transfer*, **2010**, *42*, 179.
⁴Locke, B. R., Sato, M., Sunka, P., Hoffmann, M. R., Chang, J. S., *Ind. Eng. Chem. Res.*, **2006**, *45*, 882.
⁵Bruggeman, P., Leys, C., *J. Phys. D: Appl. Phys.*, **2009**, *42*, 053001.
⁶Locke, B. R., Thagard, S. M., *Plasma Chem. Plasma Process.*, **2012**, *32*, 875.
⁷Kirkpatrick, M. J., Locke, B. R., *Ind. Eng. Chem. Res.*, **2005**, *44*, 4243.
⁸Sahni, M., Locke, B. R., *Ind. Eng. Chem. Res.*, **2006**, *45*, 5819.
⁹Lukes, P., *PhD dissertation, Institute of Chemical Technology, Prague, Czech Republic*, **2001**.
¹⁰Anpilov, A. M., Barkhudarov, E. M., Bark, Y. B., Zadiraka, Y. V., Christofi, M., Kozlov, Y. N., Kossyi, I. A., Kop'ev, V. A., Silakov, V. P., Taktakishvili, M. I., Temchin, S. M., *J. Phys. D: Appl. Phys.*, **2001**, *34*, 993.
¹¹Sunka, P., Benes, J., Lukes, P., Zadinova, M., Hoffer, P., Pouckova, P., *IEEE Int. Conf. Plasma Sci.*, **2009**, 1.
¹²Sunka, P., Babicky, V., Clupek, M., Benes, J., Pouckova, P., *IEEE Trans. Plasma Sci.*, **2004**, *32*, 1609.
¹³Roberts, R. M., Cook, J. A., Rogers, R. L., Gleeson, A. M., Griffy, T. A., *J. Acoust. Soc. Am.*, **1996**, *99*, 3465.
¹⁴Lu, X., Pan, Y., Liu, K., Liu, M., *J. Appl. Phys.*, **2002**, *91*, 24.
¹⁵Sun, B., Sato, M., Harano, A., Clements, J. S., *J. Electrostatics*, **1998**, *43*, 115.
¹⁶Buogo, S., Plocek, J., Vokurka, K., *Acta Acoustica*, **2009**, *5*, 46.
¹⁷Martinson E., Delsing, J., *Flow Measurement Instrum.*, **2010**, *21*, 394.
¹⁸Foster, J. E., Weatherford, B., Gillman, E., Yee, B., *Plasma Sources Sci. Technol.*, **2010**, *19*, 025001.

Received: 14.07.2014.
 Accepted: 28.07.2014.